



Ruijie RG-WS6512 Wireless Controller

Hardware Installation and Reference Guide

Document Version: V1.3
Date: August 16, 2023
Copyright © 2023 Ruijie
Networks

Copyright

Copyright © 2023 Ruijie Networks

All rights are reserved in this document and this statement.

Any reproduction, excerpt, backup, modification, transmission, translation or commercial use of this document or any portion of this document, in any form or by any means, without the prior written consent of Ruijie Networks is prohibited.

Trademark  and  are owned by Ruijie Networks.

All other trademarks or registered trademarks mentioned in this document are owned by their respective owners.

Disclaimer

The products, services, or features you purchase are subject to commercial contracts and terms. Some or all of the products, services or features described in this document may not be within the scope of your purchase or use. Unless otherwise agreed in the contract, Ruijie Networks does not make any express or implied statement or guarantee for the content of this document.

Due to product version upgrades or other reasons, the content of this document will be updated from time to time. Ruijie Networks reserves the right to modify the content of the document without any notice or prompt.

This manual is for reference only. Ruijie Networks endeavors to ensure content accuracy and will not shoulder any responsibility for losses and damages caused due to content omissions, inaccuracies or errors.

Preface

Intended Audience

This document is intended for:

- Network engineers
- Technical support and servicing engineers
- Network administrators





Technical Support

- Ruijie Networks Website: <https://www.ruijienetworks.com/>
- Technical Support Website: <https://ruijienetworks.com/support>
- Case Portal: <https://caseportal.ruijienetworks.com>
- Community: <https://community.ruijienetworks.com>
- Technical Support Email: service_rj@ruijienetworks.com
- Live Chat: <https://www.ruijienetworks.com/rita>

Conventions

1. Signs

The signs used in this document are described as follows:

-
-  **Warning**
- An alert that calls attention to important rules and information that if not understood or followed can result in data loss or equipment damage.
-
-  **Caution**
- An alert that calls attention to essential information that if not understood or followed can result in function failure or performance degradation.
-
-  **Note**
- An alert that contains additional or supplementary information that if not understood or followed will not lead to serious consequences.
-
-  **Specification**
- An alert that contains a description of product or version support.
-

2. Note

The manual offers configuration information (including model, port type and command line interface) for indicative purpose only. In case of any discrepancy or inconsistency between the manual and the actual version, the actual version prevails.

1 Product Introduction

1.1 Overview

The RG-WS6512 is an access controller (AC) released by Ruijie Networks. It is mainly used in medium- and large-sized wireless local area networks (WLANs) to provide powerful access control functions.

1.2 Product Appearance

Figure 1-1 Appearance of the RG-WS6512

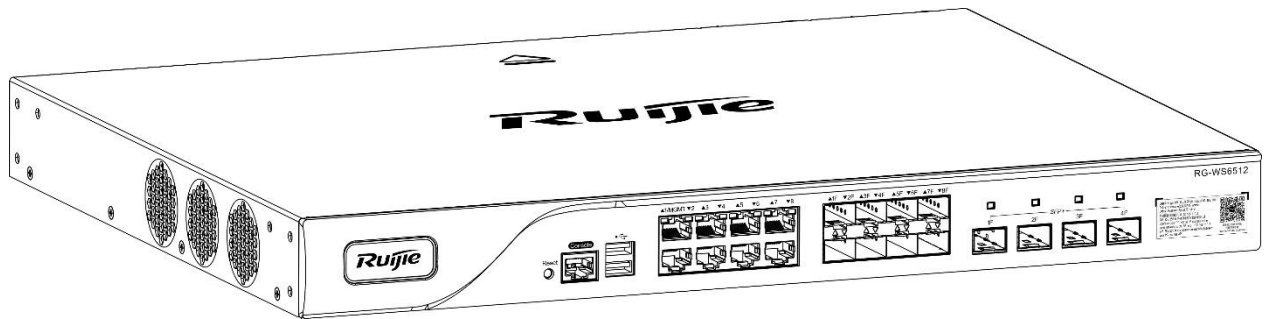

Figure 1-2 Front Panel of the RG-WS6512

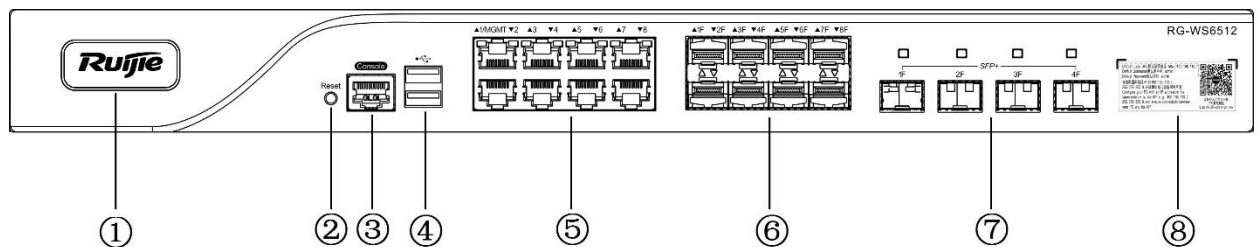
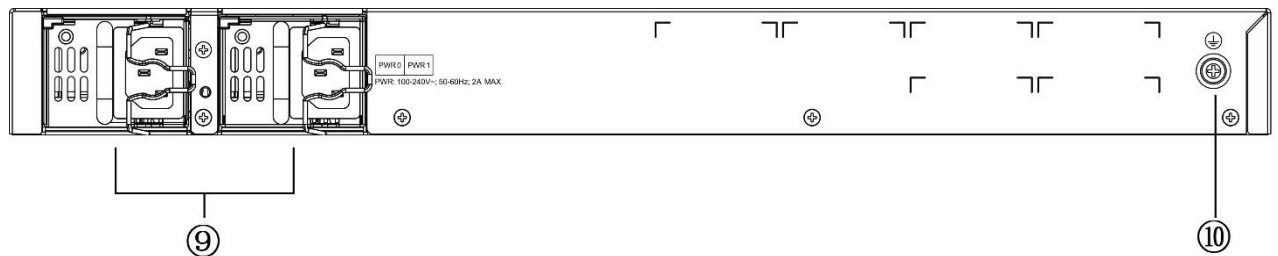

Figure 1-3 Rear Panel of the RG-WS6512



Description	1. System logo LED	6. 1000Base-X SFP combo ports
	2. Reset button	7. 10GBASE-SR/LR SFP+ ports
	3. RJ45 console port	8. QR code for Ruijie AP and AC initialization guide
	4. USB 2.0 port	9. Power modules
	5. 10/100/1000Base-T auto-sensing Ethernet ports	10. Grounding screw

Note

The nameplate is at the bottom of the access controller.

1.3 Product LED Indicators

LED	Status
System logo LED	Initializing upon power-on/Upgrading: blinking green Proper running upon initialization completion: steady green Abnormal running: steady red
LEDs for 1000 Mbps copper ports (1 to 8)	1000 Mbps link: steady green 100/10 Mbps link: steady yellow Data receiving/transmitting: blinking
LEDs for 1000 Mbps optical ports (1F to 8F)	Link: steady green Data receiving/transmitting: blinking green
LEDs for 10 Gbps optical ports (1F to 4F)	Link: steady green Data receiving/transmitting: blinking green

Pressing the Button to Reboot the System

Press the Reset button. The system is rebooted.

Press and hold the Reset button for 3s. The system is rebooted with restored default settings.

1.4 Technical Specifications

1.4.1 Dimensions and Weight

Dimensions and Weight	RG-WS6512
Dimensions (W × D × H)	440 mm × 340 mm × 43.6 mm (17.32 in. × 13.39 in. × 1.72 in.) (excluding the foot pads)
Rack height	1 U
Weight	Net weight: 5.9 kg (13.01 lbs., one power module for factory delivery)

1.4.2 Port Specifications

Item	RG-WS6512
Fixed service port	One 10/100/1000Base-T MGMT port with auto-negotiation Eight combo ports (when the combo port is used as an electrical port, it supports 10/100/1000Base-T auto-negotiation) Four 10GE SFP + ports
Fixed management port	One RJ45 console port Two USB ports
Status LED	One system LED 20 service port status LEDs
Button	One reset button

1.4.3 Power Supply and Consumption

Item	RG-WS6512
Max. power consumption	70 W
Power redundancy	Two power modules (one power module for factory delivery)

Item	RG-WS6512
Input voltage	100V AC~240V AC, 50Hz~60Hz
Output voltage	12V/5.83A

Note

A combo port consists of an optical port and an electrical port. The optical port and electrical port cannot work at the same time. If one port is enabled, the other is disabled. You can select the port type as required.

1.4.4 Environment and Reliability

Item	RG-WS6512
Temperature	<p>Operating temperature: 0°C to 45°C (32°F to 113°F)</p> <p>Storage temperature: -40°C to +70°C (-40°F to +158°F)</p> <p>At a height between 3000 m (9842.52 ft.) to 5000 m (16404.20 ft.) above the sea level, every time the altitude increases by 166 m (545 ft.), the maximum temperature decreases by 1°C (1.8°F).</p>
Humidity	<p>Operating humidity: 10% to 90% RH (non-condensing)</p> <p>Storage humidity: 5% to 95% RH (non-condensing)</p>
Regulatory Compliance	IEC 62368-1, EN 62368-1, EN 55032, EN 55035, EN 61000-3-3, EN IEC 61000-3-2, and ETSI EN 300 386
MTBF	≥ 200,000 hours

Note

Due to the variety of USB flash drives, not all of them are supported. A USB flash drive with the FAT32 file system format is recommended.

Caution

- Please avoid vibration and shock when moving and using the device.
- Before using hard disks provided by customers, format them to the EXT3 format.

- This is a Class A product. In a domestic environment, this product may cause radio interference. In this case, users are advised to take proper measures against the interference.
-

1.5 RG-PA701 Power Supply Model

1.5.1 Power Supply

Parameter	Description
Rated voltage range	100 V AC to 240 V AC
Frequency	50 Hz to 60 Hz
Rated current	2 A Max.
Power cord	10 A power cord
Current equalization	Supported

The RG-WS6512 adopts AC input and supports power module redundancy.

1.5.2 Power LED

LED	Status
DC OK	Normal input: steady green Abnormal input: off

Warning

The circuit breaker in the power module cannot be removed.

2 Preparing for Installation

2.1 Precautions

An AC functions as a transfer station for network connections. Its functionality is related to the normal operation of the entire network. When installing and using the RG-WS6512, pay attention to the following safety recommendations:

- Do not place the device in a wet position, and keep the device away from liquid.
- Install the device in a position far away from heat sources.
- Ensure that the device is properly grounded.
- Wear an anti-static wrist strap during installation and maintenance.
- Do not wear loose clothing, which may be hooked by the device, thereby causing damage to the device. Fasten your belt and scarf, and tie your sleeves.
- Keep tools and components away from walking areas to prevent collisions.
- An uninterrupted power supply (UPS) is recommended to prevent power outage and interference.
- If the clock read from the device is inaccurate, check whether the clock of the device has been set. If the clock has not been set, the clock read from the device may be inaccurate. If the clock of the device has been set accurately, the button battery inside the device may be exhausted. A button battery can be generally used for about 10 years. After the battery is exhausted, the clock will be inaccurate.
- To ensure normal running of the device, see storage temperature and humidity specifications.

Caution

- An improper type of battery can cause damage and danger to the device. To replace the battery, contact Ruijie technical support.
 - This device is not suitable for use in locations where children are likely to be present.
 - This is a Class A product. In a domestic environment, this product may cause radio interference. In this case, users are advised to take proper measures against the interference.
 - If the device has been powered off for over 18 months, power on the device and keep it run for over 24 hours consistently.
-

Note

- Install the device in a location with restricted access.
- The device is a professional device and requires professionals or related technical personnel to install it.

2.2 Installation Environment Requirements

The RG-WS6512 must be installed indoors. To ensure its normal operation and prolonged service life, the installation site should meet the following requirements.

2.2.1 Temperature/Humidity Requirements

To ensure the normal operation and prolonged service life of the device, maintain an appropriate temperature and humidity in the equipment room. If the humidity in the equipment room keeps high for a long time, some mechanical performance issues may occur, such as the poor insulation of insulating materials and even electric leakage. If the relative humidity is too low, the insulating gasket may shrink and cause the fixed screws to loosen. Moreover, it is easy to generate static electricity and harm the circuits in the device. Too high temperatures can accelerate the aging of insulation materials, greatly reducing the reliability of the device and severely affecting its service life. The following table provides the temperature and humidity requirements. (The related specifications in Chapter 1 prevail.)

Temperature		Relative Humidity	
Long-Term Operating	Short-Term Operating	Long-Term Operating	Short-Term Operating
15°C to 30°C (59°F to 86°F)	0°C to 45°C (32°F to 113°F)	40% to 65%	10% to 90%

Note

The ambient temperature and humidity of the device are measured at the point that is 1.5 m (59.06 in.) above the floor and 0.4 m (15.75 in.) before the device when there is no protective plate in front or at the back of the device.

Short-term operating indicates that the device functions for no more than consecutive 48 hours or accumulated 15 days per year.

The temperature and humidity ranges in extremely severe environments generally refer to the possible values in an equipment room where the air-conditioning system fails and is recovered in no more than 5 hours each time.

2.2.2 Cleanliness Requirements

Dust poses a major threat to the device. Indoor dust causes electrostatic adherence when falling on the device, resulting in poor contact. Such electrostatic adherence may occur more easily when the relative humidity is low, not only affecting the service life of the device, but also causing communication faults.

Max. Diameter (μm)	0.5	1	3	5
Max. Concentration (Particle Quantity/ m^3)	1.4×10^7	7×10^5	2.4×10^5	1.3×10^5

Apart from dust, the sulfide in the air in the equipment room must also meet strict requirements. These harmful substances will accelerate metal corrosion and the aging of some components. Therefore, the equipment room should be properly protected against the intrusion of harmful gases, such as sulfur dioxide, hydrogen sulfide, nitrogen dioxide, ammonia gas, and chlorine gas. The following table lists limit values for harmful gases.

Gas	Average (mg/m^3)	Maximum (mg/m^3)
Sulfur dioxide (SO ₂)	0.2	1.5
Hydrogen sulfide (H ₂ S)	0.006	0.03
Nitrogen dioxide (NO ₂)	0.04	0.15
Ammonia gas (NH ₃)	0.05	0.15
Chlorine gas (Cl ₂)	0.01	0.3

2.2.3 Anti-static Requirements

Although the anti-static treatment has been applied to the RG-WS6512 during the circuit design, strong static electricity will still cause damage to the circuit board. Regarding the communication network connected with the device, static electricity mainly comes from the following two aspects:

- Outdoor high-voltage power cables, lightning, and other external electric fields
- Indoor floor materials and the internal structure of the device

To prevent damage from static electricity, pay attention to the following:

- Properly ground the device and floor.

- Keep the indoor installation environment clean and free of dust.
- Maintain the appropriate temperature and humidity.
- Wear the anti-static wrist strap and anti-static clothing when touching the circuit board of the device.
- Place the disassembled circuit board facing up on an anti-static workbench or put it in an electromagnetic shielding bag.
- When observing or transferring the disassembled circuit board of the RG-WS6512, hold the outer edges of the circuit board with your hands to avoid directly touching the components on the circuit board.

2.2.4 Anti-interference Requirements

Anti-interference herein refers to resistance against electromagnetic and current interference. The anti-interference requirements are as follows:

- Take interference prevention measures for the power supply system.
- Keep the device far away from the lightning protection and grounding system of the power device.
- Keep the device far away from high-frequency high-current devices such as high-power radio transmitting station and radar launcher.
- Take electromagnetic shielding measures when necessary.

2.2.5 Other Requirements

Regardless of whether the device is installed in a cabinet or placed on a workbench, the following conditions must be met:

- Maintain sufficient clearance around the air vents for heat dissipation. It is recommended to install the device in a 19-inch standard cabinet. Otherwise, place the device horizontally on a clean panel. It is recommended to install air conditioners in hot areas.
- The ventilation and heat dissipation of the cabinet and workbench are satisfactory.
- The cabinet or the workbench is strong enough to support the weight of the device and its accessories.
- The cabinet or the workbench are properly grounded.

2.3 Tools and Relevant Devices

Before installing the device, prepare the following tools and relevant devices:

Tools	Phillips screwdriver and anti-static wrist strap
Cables	Power cord, RJ45 serial cable, Ethernet cable, and ground cable

Relevant Devices	Hub or switch, configuration terminal (such as a PC with HyperTerminal), and power socket
-------------------------	---

3 Installing the AC

3.1 Installation Procedure

To avoid device damage caused by any improper operation during the installation process, install the device according to the procedure shown in the following figure.

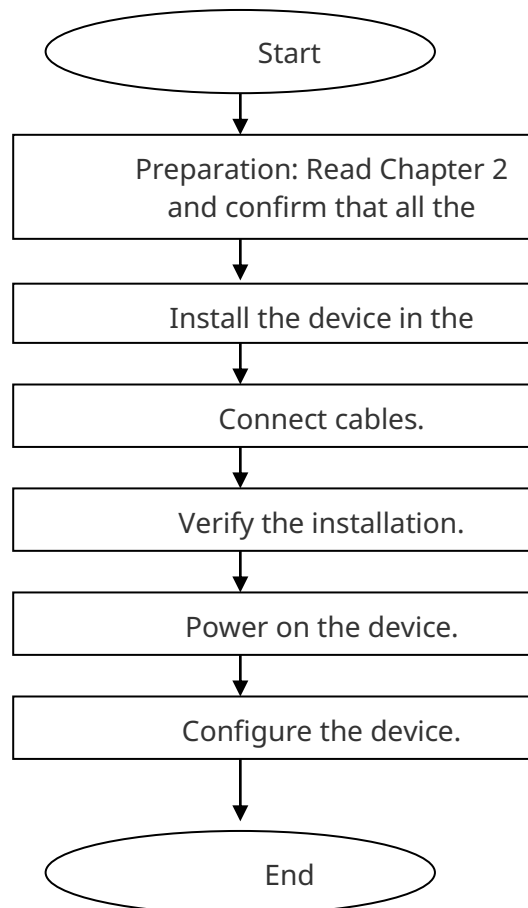

3.2 Securing the AC

Install the device in the specified location. After completing the installation preparations, secure the device to the specified location. The device is generally installed in the following locations:

Installing the Device in a Cabinet

The device is designed according to the dimensions of a standard cabinet, and can be installed and secured with the delivered accessories based on the cabinet condition.

Installing the Device on a Workbench

In most cases, a 19-inch standard cabinet is unavailable. Therefore, a simple way is to place the device on a clean workbench. During the process, pay attention to the following:

- Ensure that the workbench is stable and properly grounded.
- Attach the plastic pads delivered with the device to the corresponding marks on the bottom of the device, while leaving a clearance of 10 cm (3.94 in.) around the device for heat dissipation.
- Do not place heavy objects on the device.

3.3 Installing the Power Cord

The RG-WS6512 supports AC power supply (100 V to 240 V/50 Hz to 60 Hz) The selected power supply modules must meet the system power requirements.

Note

For details about the power supply types supported by the device, see Chapter 1.

The power cord of the RG-WS6512 has three cores. You are advised to use a single-phase three-core power socket or a multi-function power socket with a neutral point connector. The neutral point of the power supply must be well grounded in the building. In general, the power supply neutral point of the building has been buried in the ground during the cabling. Users need to confirm whether the power supply of the building has been properly grounded.

Connect the power cord by performing the following steps:

- Plug one end of the power cord into the power socket on the rear panel of the device and the other end of the power cord into the AC power socket.
- Check the status of power LED on the front panel of the device. If the LED is on, the power cord is connected correctly.

3.4 EMC Grounding

Grounding required for electromagnetic compatibility includes shielded grounding, filter grounding, noise and interference suppression, and level reference, which contribute to the overall grounding requirements. The grounding resistance should be smaller than 1 ohm. The rear panel has a grounding stud, as shown in Figure 3-1.

Figure 3-1 Grounding

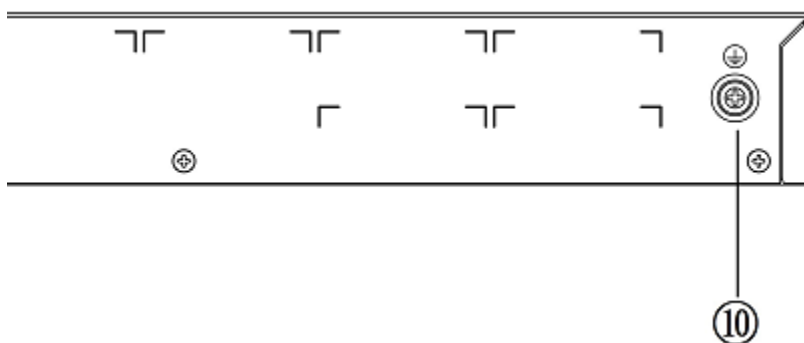

3.5 Connecting to the Console

The RG-WS6512 has an EIA/TIA-232 asynchronous serial console port, which allows users to complete the local configuration of the RG-WS6512. The following table provides the details about the console port. If the RG-WS6512 is configured by using the web, there is no need to connect to the console.

Parameter	Description
Connector	RJ-45
Interface Standard	Asynchronous EIA/TIA-232
Baud Rate	9600 bps (default), 57600 bps, and 115200 bps
Supported Services	<ol style="list-style-type: none">1. CLI2. Connection to character terminals3. Asynchronous interface for terminal access

Users can connect to the console port of the RG-WS6512 based on the following procedure:

Connect one end of the RJ45 serial cable delivered with the RG-WS6512 to the console port, and the other end to the DB-9 male connector of the microcomputer that is used to configure the AC.

3.6 Verifying the Installation

After the mechanical installation of the RG-WS6512 is completed, check the following items before powering on the RG-WS6512:

- If the device is installed inside a cabinet, verify that the cabinet and mounting ears are secured. If the device is placed on a workbench, verify that sufficient space for heat dissipation is reserved around the device and the workbench is steady.
- Verify that the power supply connected to the power cord meets the requirements of the device.
- Verify that the ground cable of the device is correctly connected.
- Verify that the device is correctly connected to other devices, such as the configuration terminal.

4 Verifying Operating Status

4.1 Setting Up the Configuration Environment

When the AC is used for the first time, it must be configured by using the console port. The specific steps are as follows:

- Step 1: Connect the serial port of a character terminal or microcomputer to the console port (also called configuration port or control panel port) of the RG-WS6512 by using a standard RS232 cable.
- Step 2: Configure the communication parameters of the terminal. If a microcomputer is used, a terminal emulation program, such as the HyperTerminal provided by the Windows operating system, must be running. HyperTerminal is used as an example to describe the procedure:
 1. Run the HyperTerminal software to create a connection.
 2. Select the serial port to connect with the console port of the RG-WS6512.
 3. Configure the communication parameters. By default, the baud rate is set to **9600**, data bit to **8**, no parity check, stop bit to **1**, and no flow control.
 4. Choose **File > Properties > Settings** and set **Terminal Emulation** to **VT100**.

Figure 4-1 Creating a Connection



Figure 4-2 Selecting the Serial Port



Figure 4-3 Configuring the Communication Parameters of the Serial Port

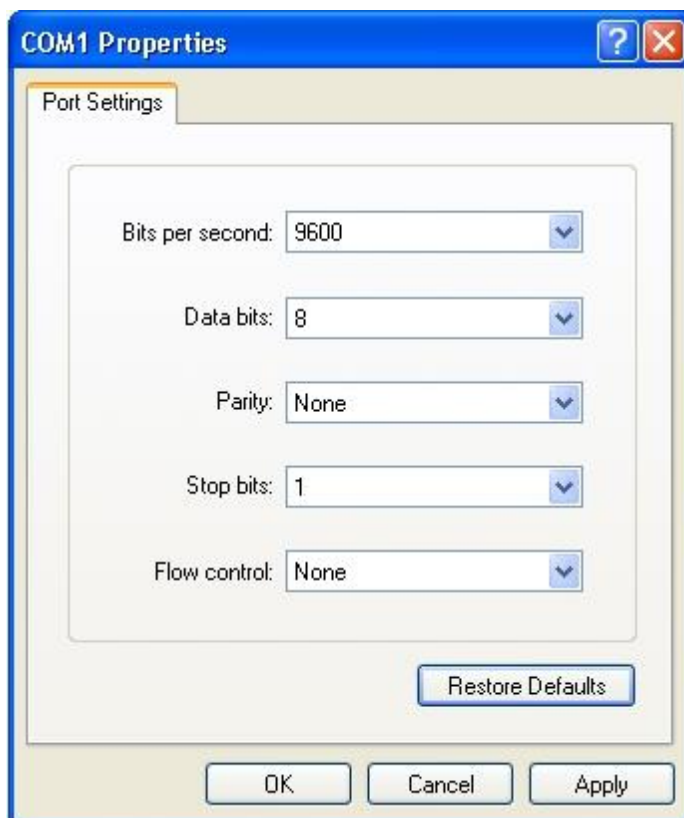

After the environment is set up, the RG-WS6512 can be powered on.

4.2 Powering On and Starting the Device

Checking Before Power-on

Before powering on the RG-WS6512, check the following items:

- Check whether the power cable and ground cable are correctly connected.

- Check whether the power supply voltage meets the requirements of the RG-WS6512.
- Check whether the RJ45 serial cable is correctly connected, and whether the microcomputer or terminal is started and configured.

Caution

Before powering on the RG-WS6512, confirm the position of the power supply switch of the RG-WS6512, so that the power supply can be cut off in a timely manner in the event of an accident.

Powering on the RG-WS6512

- Turn on the power supply switch of the RG-WS6512.

Checking After Power-on

After the RG-WS6512 is powered on, check the following items:

- Check whether the ventilation system is normal.

(Method: After the RG-WS6512 is powered on, you should be able to hear the sound from fan rotating and you can feel the flow of air by placing your hand near the air vents of the RG-WS6512.)

- Check whether the LEDs on the front panel of the RG-WS6512 are normal.

(Method: See the section about LEDs in Chapter 1.)

- Check whether the configuration terminal has normal display.

(Method: After the RG-WS6512 is powered on, the configuration terminal will display information about software self-extracting of the RG-WS6512.)

Starting the RG-WS6512

When the RG-WS6512 is started for the first time, information similar to the following content about self-extracting is displayed:

```
*****
Boot 1.2.6-00386-g6849a86 (Build time: Oct 13 2014 - 17:40:17)

DRAM: 16 GiB
NAND: 512 MiB
Flash: 8 MiB
SETMAC: Setmac operation was performed at 2015-03-04 16:42:48 (version: 11.0)
Press Ctrl+C to enter Boot Menu
Bootloader: Done loading app on coremask: 0xffffffff
Starting Devices Initializations... [ OK ]

adding user rgosm...
adding user guest...
adding user sslvpn...
adding user postgres...
```

```
insmod: cannot insert `/sbin/rg-console.ko': File exists (-1): File exists*Mar  4 16:46:37: %SYS-5-  
AC_POWER_ON: System coldstart.
```

Press RETURN to get started

Ruijie>

Then, you can configure the RG-WS6512.

 **Note**

The preceding self-extracting information is used as an example. The actual information varies with different hardware or software versions.

If the RG-WS6512 is used for the first time, it is recommended to configure some basic parameters of the RG-WS6512.

5 Troubleshooting

5.1 Power Failures

Check the power LED of the power module to determine whether the power system of the RG-WS6512 fails. For the normal LED status, see Chapter 1. If an exception occurs, perform the following operations:

- Check whether the power supply switch of the RG-WS6512 is turned on.
- Check whether the power cord of the RG-WS6512 is correctly connected.
- Check whether the power supply is the same as that required by the RG-WS6512.

Caution

Do not plug and insert the power cord with the power supply switch turned on. If no exception is found but the power LED is still off, contact the local distributor or Ruijie technical support.

5.2 Configuration System Failures

Symptom	Possible Cause	Solution
Forgotten password for management interface login		Contact the Ruijie technical support.
Off system LED after power-on	The power supply is not working.	Check whether the power supply socket in the equipment room is normal and whether the power supply is properly connected with the device.
Red system LED	The device is equipped with two power modules, but only the 220 V power module normally supplies power and the power cord of the other power module is not properly connected. The fan is faulty.	Check whether the power cord is properly connected. Check the ambient environment of the device, clean the dust on the device, lower the ambient temperature. Check whether the fans are properly rotating.

	The ambient temperature is too high.	
Garble characters or no output on the serial port-based console	<p>The serial port used by the configuration software is inconsistent with the serial port connected on the AC.</p> <p>The serial port is incorrectly configured.</p>	<p>Change the serial port used by the configuration software to the serial port connected on the AC.</p> <p>Check whether the serial port is configured based on the required parameter settings for the serial port.</p>
Frame RX/TX errors or connection failures of the RJ45 connector	<p>The twisted pair cable is faulty.</p> <p>The cable length exceeds 100 meters.</p> <p>The port has special configuration and does not have a common operating mode with the interconnected AC.</p>	<p>Replace the twisted pair cable.</p> <p>Check the port configuration and check whether the port has a common operating mode with the interconnected AC.</p>
Optical port connection failure	<p>The RX and TX ends are incorrectly connected.</p> <p>The types of the interconnected optical modules are not matched.</p> <p>The optical fiber type does not meet the related requirements.</p> <p>The optical fiber length exceeds the upper limit of the optical module.</p>	<p>Exchange the RX and TX ends of the optical fiber.</p> <p>Change the interconnected optical modules to the same type.</p> <p>Use an optical fiber that meets the related requirements.</p> <p>Use an optical fiber whose length meets the related requirements.</p>

